



QUALITY POLICY OF CMI OI PRAGUE

The Czech Metrology Institute (CMI) – Regional Inspectorate (RI) Prague is possessor of the national standard of unit of radioactivity - Bq. It is in the system of metrology of radioactivity the top facility in the Czech Republic. Working of the laboratory of absolute measurements is verified by system of international comparisons, which guarantees highest level of quality control.

To secure of metrological linking-up on radioactivity standard, RI manufactures wide scale of secondary standards, covering comprehensive spectrum of needs of labs for radioactivity measurement, labs of nuclear medicine, hygienic labs and for needs of legal metrology. Our aim is by means of secondary standards of highest class to improve system of metrology of radioactivity and in the highest possible degree to satisfy the client's requirements and aim at increase in quality and technical level of products. At response on market requirements, we are able to develop and produce completely new types of standards.

CMI RI Prague, Department of Radioactive Standards Production has been found to conform to the Quality Management System standard: ISO 9001:2015. This certificate is valid for the following scope: Development and production of secondary standards of radionuclides, production of dosimetric diodes for measuring of the fast neutron dose and measurement of activity of radionuclides and checking tightness of sealed radioactive sources. Quality management system is checked by independent company DNV.

Quality System Certificate DNV No. 253683-2018-AQ-CZS-RvA (ISO 9001:2015).



Producer, technical support, consultation:

Czech Metrology Institute – Regional Inspectorate Prague

Department of Radionuclide Standards

Radiová 1288/1a

102 00 Praha 10

tel.: 266 020 460, 266 020 412

e-mail: dominika.sosnova@cmi.gov.cz ; vlasta.sukova@cmi.gov.cz

PRODUCT CATALOG OF CMI - OI PRAGUE

Producer
Český metrologický institut,
Oblastní inspektorát Praha

Czech Metrology Institute
Regional Inspectorate Prague

Department of Radionuclide Standards Production

Radiová 1288/1a

102 00 Praha 10

tel.: 266 020 460, 266 020 412

e-mail: dominika.sosnova@cmi.gov.cz,
vlasta.sukova@cmi.gov.cz

Standards for alpha spectrometry	EA / EAP
Standards for X and gamma spectrometry	EFF, EFX, EFS
Etalony pro spektrometrii záření gama	EFRa
Standards for checking and calibration gamma spectrometers	EG, EGA, MBSS/CBSS
Standards for checking and calibration devices for measurement of area contamination	EM, EZ
Standards for checking devices for measurement of area contamination	EMM, EZM
Standards of mass ²²⁶ Ra	EB, EP
Standards in solution for general use	ER
Simulator ¹²⁵ I for checking and calibration RIA measuring devices	ESI
Standards for use in nuclear medicine	ENM, ED, ENK / ENKV
Phantom BOMAB	BOMAB
Flow through sources of ²²² Rn	RF / RFE
Simulator of radioactive contaminated steel	ES
Standards type filter	FILTER
Methyl iodide labelled with ¹³¹ I	EMEI

Expalanation:

Uncertainty is an abbreviation for combined standard uncertainty (P = 68,27 %).

⁹⁰Sr is in radioactive equilibrium with ⁹⁰Y.

¹³⁷Cs is in radioactive equilibrium with ^{137m}Ba.

Half-lives, particle energies a their yields were taken from tables “**Laboratoire National Henry Becquerel Recommended Data**” http://www.nucleide.org/DDEP_WG/DDEPdata.htm or NuDat <http://www.nndc.bnl.gov/nudat2/>.

Listed values of activity, uncertainty etc. are nominaly values and it is possible to change them for specific product. Activity values of products are in range + 30% / - 10% of nominaly values.

STANDARDS TYPE EA

Standards type EA are open radioactive sources. The radioactive substance is electrolytically deposited in thin layer on the Pt foil. The foil is squeezed into the duraluminium casing with dimensions 25 x 5 mm (diameter x height).

They are widely used as control sources in comparative measurements, for energy and efficiency calibration of α -spectrometers, determination of efficiency of window and windowless counters of α particles.

Flux of α particles to spatial angle 2π sr is determined by 2π windowless proportional counter.

Activity is calculated from flux using correction on back scattering, spatial angle and self-absorption.

In the table below are normally used radionuclides and their activities. It is possible to produce another activities after consultation as EA X.

Nuclide	Half life [years]	Particle energy [keV]	Type	Particle flux in 2π sr [s^{-1}]	Nominal uncertainty of flux [%]	Nominal activity [kBq]	Nominal uncertainty of activity [%]	code	Certificate validity period
^{239}Pu	24100 (11)	5105,81	EA 13	51	1,3	0,1	2,1	PUA 13	3 years
		5143,82 5156,59	EA 14	510	1,3	1,0	2,0	PUA 14	3 years
^{241}Am	432,6 (6)	5442,86	EA 13	51	1,3	0,1	2,1	AMA 13	3 years
		5485,56	EA 14	510	1,3	1,0	2,0	AMA 14	3 years
			EA 15	5100	1,3	10	2,0	AMA 15	3 years
$^{241}\text{Am} + ^{239}\text{Pu}$	-	-	EA 14	510	1,3	1,0	2,1	AMPU 14	3 years

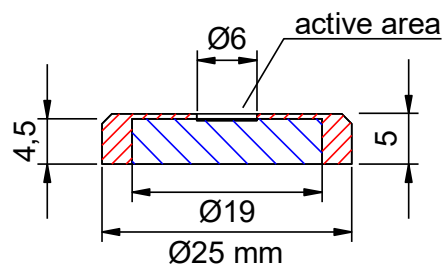

STANDARDS TYPE EAP

Standards type EA are open radioactive sources. The radioactive substance is electrolytically deposited in thin layer on the Pt foil.

They are widely used as control sources in comparative measurements, for energy and efficiency calibration of α -spectrometers, determination of efficiency of window and windowless counters of α particles.

Flux of α particles to spatial angle 2π sr is determined by 2π windowless proportional counter.

Activity is calculated from flux using correction on back scattering, spatial angle and self-absorption.

In the table below are normally used radionuclides and their activities. It is possible to produce another activities after consultation as EAP X

Nuclide	Half life [years]	Particle energy [keV]	Type	Particle flux in 2π sr [s^{-1}]	Nominal uncertainty of flux [%]	Nominal activity [kBq]	Nominal uncertainty of activity [%]	Certificate validity period
^{239}Pu	24100 (11)	5105,81 5143,82 5156,59	EAP 13	51	1,3	0,1	2,1	3 years
			EAP 14	510	1,3	1,0	2,0	3 years
^{241}Am	432,6 (6)	5442,86 5485,56	EAP 13	51	1,3	0,1	2,1	3 years
			EAP 14	510	1,3	1,0	2,0	3 years
			EAP 15	5100	1,3	10	2,0	3 years
$^{241}\text{Am} + ^{239}\text{Pu}$	-	-	EAP 14	510	1,3	1,0	2,1	3 years

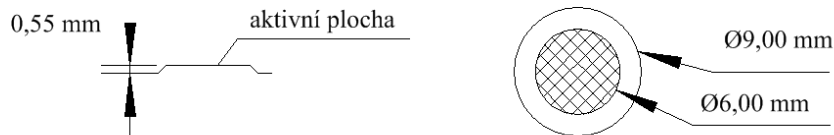

Note: Active area is crossed out, thickness of sheet of Pt is 0,1 mm.

STANDARDS TYPE EFF A EFX

Standards of X and γ photon flux type EFF and EFX are the point sources with minimum self-absorption emitting homogeneously to angle near 4π sr. The activity is deposited between two welded polyethylene foils with square weight $3,6 + 0,3 \text{ mg}\cdot\text{cm}^{-2}$. The foils are located in the metal ring with outer diameter 40 mm. The active material is located in the center of the foil. Standards type EFF and EFX are open radioactive sources.

Standards EFF and EFX are designed for energy and efficiency calibration of counters and spectrometers of X and γ photons. The activity of the standard gives the source strength approximately $\sim 10^4 \text{ s}^{-1}$.

The source strength of the EFX standard is determined by means of a suitable 4π counter. For the standards EFF (emitting photons γ) source emission is calculated from the activity and the known photon yields

The activity of the standard is calculated from the mass and specific activity of the standard solution.

In the table below are normally used radionuclides and their activities.

Nuclide	Half-life	Photon energy [keV]		Particle flux in 4π sr		Code	Certificate validity period
		X _K	γ	[keV]	[s ⁻¹]		
⁵⁵ Fe	2,747 (8) years	5,88-6,54	-	5,88-6,54	10 ⁴	FMFX	3 years
⁵⁷ Co	271,81 (4) days	6,39-7,11	122,06	122,06	10 ⁴	CTFF	2 years
			136,47	136,47			
⁶⁵ Zn	244,01 (9) days	8,03-8,98	1115,5	8,03- 8,98	10 ⁴	ZNFX	2 years
⁸⁵ Sr	64,850 (7) days	13,34-15,21	514,00	13,34-15,21 X _K	10 ⁴	SAFX	1 year
¹⁰⁹ Cd	461,9 (4) days	21,99-25,51	88,034	21,99-25,51 X _K	10 ⁴	CDFX	3 years
²⁴¹ Am	432,6 (6) years	11,89-22,2 X _L	26,34	59,54	10 ⁴	AMFF	6 months
			59,54				

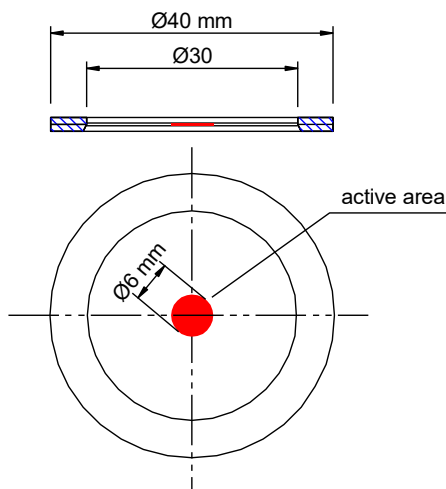

STANDARDS TYPE EFS

Standards of γ photon flux EFS are the point sources with minimum self-absorption emitting homogeneously to angle near 4π sr. The activity is deposited between two welded polyethylene foils with thickness less than 0,2 mm. Foils are mounted in the metal ring with outer diameter 35 mm. The active material is located in the center of the foil. Standards type EFS are open radioactive sources.

The standards EFS are designed for energy and efficiency calibration of gamma spectrometers in range 100 keV - 2 MeV.

The activity of the standard is calculated from the specific activity and mass of the standardized solution.

In the table below are normally used radionuclides and their activities. It is possible after consultation to produce sources with another radionuclides or activities as EFS X.

Nuclide	Half-life	Photon energy [keV]	Photon yield [%]	Nominal activity [kBq]	Nominal uncertainty activity [%]	Nominal activity [kBq]	Code	Certificate validity period
⁵⁷ Co	271,81 (4) days	122,06	85,51	50	1,2	50	CTS 01	2 years
		136,47	10,71					
¹³⁹ Ce	137,641 (20)	165,858	79,90	80	1,2	80	CCS 01	2 years
⁵¹ Cr	27,704 (4) days	320,084	9,89	500	1,6	500	CRS 01	6 months
⁸⁵ Sr	64,850 (7) days	514,0	98,5	250	1,2	250	SAS 01	1 year
¹³⁷ Cs	30,05 (8) years	661,657	84,99	400	1,2	400	CSS 01	2 years
⁵⁴ Mn	312,19 (3) days	834,85	99,975	450	1,0	450	MNS 01	2 years
⁶⁰ Co	5,2711 (8) years	1173,23	99,85	700	0,8	700	COS 01	2 r years
		1332,49	99,983					
⁸⁸ Y	106,63 (5) days	898,042	93,70	700	1,5	700	YWS 01	2 years
		1836,07	99,35					
¹³³ Ba	10,539 (6) years	53,162	2,14	250	1,0	250	BAS 01	2 years
		79,614	2,63					
		80,998	33,31					
		160,612	0,638					
		223,237	0,450					
		276,399	7,13					
		302,851	18,31					
		356,013	62,05					
383,849	8,94							
¹⁵² Eu	13,522 (16) years	121,782	28,41	600	1,0	600	EUS 01	2 years
		244,697	7,55					
		344,279	26,59					
		411,117	2,238					
		443,965	2,80					
		778,905	12,97					
		964,079	14,50					
		1085,84	10,13					
		1112,08	13,41					
1408,01	20,85							

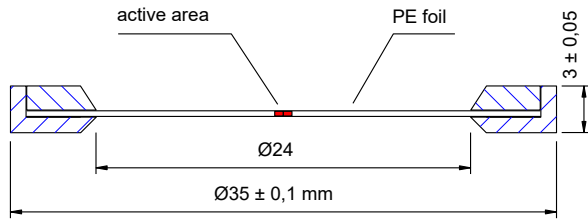

STANDARDS TYPE EFRA

Standards type EFRA are the point sources with minimum self-absorption emitting homogeneously to angle near 4π sr. Standard are designed for ^{226}Ra . The activity is deposited between two welded three-layer polyethylene foils with Al-layer ((ALU PPL 128, aeric mass $12,8 \text{ mg}\cdot\text{cm}^{-2}$). Foils are mounted in the metal ring with outer diameter 40 mm. The active material is located in the center of the foil.

Standards EFRA are sealed radioactive sources with classification ISO/14/C21222 according to ISO 2919. Leak tests are made according to ISO 9978 (emanation test).

The standards EFRA are designed for energy and efficiency calibration of gamma spectrometers.

The activity of the standard is calculated from the specific activity and mass of the standardized solution. Standards are produced with activity range from 1 kBq to 10 kBq. Other activities are also possible.

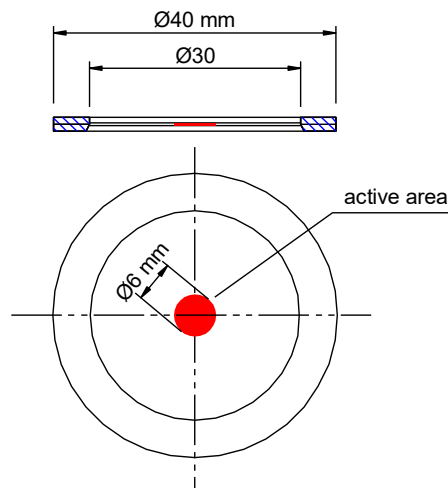

SOURCES TYPE EG

Standards type EG are point sources. The weighed amount of the standardized solution is dropped on the filter paper in the polystyrene capsule. After drying out, the capsule is sealed by an epoxy adhesive. The capsule and the reflector layer of common NaI(Tl) scintillators provide a sufficient filtering of α and β radiation of relevant radionuclide. For ^{144}Ce this filtration is not sufficient and for the types EG 1 and EG 3 layer of minimum 3,2 mm Al between the standard and the detector is necessary.

The capsule of EG 1 and EG 3 has shape of disc with dimensions ϕ 25 x 3 mm (diameter x thickness), the capsule of EG 2 has shape of cylinder with dimensions ϕ 12 x 60 mm (diameter x length).

Standards EG are sealed radioactive sources with classification ISO/14/C12133 according to ISO 2919. Leak tests are made according to ISO 9978 (wet wipe test).

Energy and efficiency calibration of scintillation spectrometers and counters of γ and X radiation. They can serve as reference sources for relative measurements. Their activity is chosen so that: standard EG 1 in closed geometry with the NaI(Tl) 38 x 25 mm; standard EG 2 inserted to the well of NaI(Tl) 45 x 50 mm and standard EG 3 located 10 cm from the forehead of NaI(Tl) 38 x 25 mm gives approx. 1700 counts per second for energy higher than 30 keV.

The activity of the standard is calculated from the specific activity and mass of the standardized solution and is checked by relative measurements of γ photon flux. The specific activity is determined by absolute measurement using 4π β - γ , 4π α - γ or 4π X- γ coincidence method or 4π proportional counter.

In the table below are normally used radionuclides and their activities. It is possible after consultation to produce sources with another radionuclides or activities as EG X.

Nuclide	Half-life	Type	Nominal activity [kBq]	Photon energy [keV]	Photon yield [%]	Nominal uncertainty activity [%]	Code	Certificate validity period
^{22}Na	2,6029 (8) years	EG 1	5	511,0 1274,537	180,7 99,94	1,0	NAG - 1	3 years
		EG 2	3				NAG - 2	3 years
		EG 3	100				NAG - 3	3 years
^{54}Mn	312,19 (3) days	EG 1	13	834,848	99,9752	0,7	MNG - 1	3 years
		EG 2	6				MNG - 2	3 years
		EG 3	300				MNG - 3	3 years
^{57}Co	271,81 (4) days	EG 1	6	122,0606 136,4735	85,51 10,71	1,0	CTG - 1	3 years
		EG 2	2				CTG - 2	3 years
		EG 3	150				CTG - 3	3 years
^{60}Co	5,2711 (8) years	EG 1	10	1173,228 1332,492	99,85 99,9826	0,7	COG - 1	3 years
		EG 2	4				COG - 2	3 years
		EG 3	200				COG - 3	3 years
^{65}Zn	244,01 (9) days	EG 1	40	1115,539	50,22	1,6	ZNG - 1	3 years
		EG 2	18				ZNG - 2	3 years
		EG 3	800				ZNG - 3	3 years
^{88}Y	106,63 (5) days	EG 1	8	898,042 1836,070	93,7 99,35	1,2	YWG - 1	3 years
		EG 2	4				YWG - 2	3 years
		EG 3	200				YWG - 3	3 years
^{129}I	16,1 (7) E+06 years	EG 1	15	39,578 29 - 35 X _K	7,42 > 69	2,5	IZG - 1	3 years
		EG 2	5				IZG - 2	3 years

Nuclide	Half-life	Type	Nominal activity [kBq]	Photon energy [keV]	Photon yield [%]	Nominal uncertainty activity [%]	Code	Certificate validity period
¹³³ Ba	10,539 (6) years	EG 1	3	80,9979	33,31	0,8	BAG - 1	3 years
		EG 2	2	302,8508	18,31		BAG - 2	3 years
		EG 3	80	356,0129	62,05		BAG - 3	3 years
¹³⁷ Cs	30,05 (8) years	EG 1	16	661,657	84,99	0,9	CSG - 1	3 years
		EG 2	7				CSG - 2	3 years
		EG 3	300				CKG - 3	3 years
¹⁵² Eu	13,522 (16) years	EG 1	30	od 121 do 1528 keV	depends on energy	0,8	EUG - 1	3 years
		EG 2	15				EUG - 2	3 years
		EG 3	450				EUG - 3	3 years
²⁴¹ Am	432,6 (6) years	EG 1	15	59,5409	35,92	0,6	AMG - 1	3 years
		EG 2	5				AMG - 2	3 years
		EG 3	450				AMG - 3	3 years

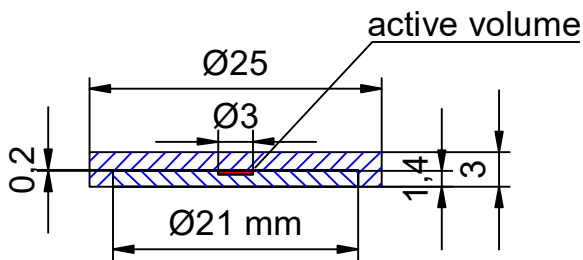

Type EG 1 and EG 3

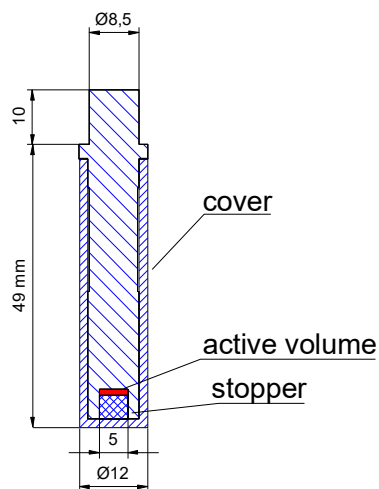

Type EG 2

STANDARDS TYPE EGA

Standards EGA are point sources. A weighed amount of the standard solution is dropped on the disc of filter paper in the ABS capsule (Akrylonitrilbutadienstyren). The capsule is sealed up, when dried. The capsule and the reflector layer of common NaI(Tl) scintillators provide a sufficient filtering of α and β radiation of relevant radionuclide. For ^{144}Ce this filtration is not sufficient and for the types EGA 1 and EGA 3 layer of minimum 3,2 mm Al between the standard and the detector is necessary. The capsule of EGA 1 and EGA 3 has shape of disc with dimensions ϕ 25 x 3 mm (diameter x thickness).

Standards EGA are sealed radioactive sources with classification ISO/14/C23343 according to ISO 2919. Leak tests are made according to ISO 9978 (wet wipe test).

Energy and efficiency calibration of scintillation spectrometers and counters of γ and X radiation. They can serve as reference sources for relative measurements. Their activity is chosen so that: standard EG 1 in closed geometry with the NaI(Tl) 38 x 25 and standard EG 3 located 10 cm from the forehead of NaI(Tl) 38 x 25 mm gives approx. 1700 counts per second for energy higher than 30 keV.

The activity of the standard is calculated from the specific activity and mass of the standardized solution and is checked by relative measurements of γ photon flux. The specific activity is determined by absolute measurement using 4π β - γ , 4π α - γ or 4π X- γ coincidence method or 4π proportional counter.

In the table below are normally used radionuclides and their activities. It is possible after consultation to produce sources with another radionuclides as EGA X or activities as EGA 1X or EGA 3X.

Nuclide	Half-life	Type	Nominal activity [kBq]	Photon energy [keV]	Photon yield [%]	Nominal uncertainty activity [%]	Certificate validity period
^{22}Na	2,6029 (8) years	EGA 1	5	511,0	180,7	1,0	3 years
		EGA 3	100	1274,537	99,94		3 years
^{54}Mn	312,19 (3) days	EGA 1	13	834,848	99,9752	0,7	3 years
		EGA 3	300				3 years
^{57}Co	271,81 (4) days	EGA 1	6	122,0606	85,51	1,0	3 years
		EGA 3	150	136,4735	10,71		3 years
^{60}Co	5,2711 (8) years	EGA 1	10	1173,228	99,85	0,7	3 years
		EGA 3	200	1332,492	99,9826		3 years
^{65}Zn	244,01 (9) days	EGA 1	40	1115,539	50,22	1,6	3 years
		EGA 3	800				3 years
^{88}Y	106,63 (5) days	EGA 1	8	898,042	93,7	1,2	3 years
		EGA 3	200	1836,070	99,35		3 years
^{129}I	16,1 (7) E+06 years	EGA 1	15	39,578 29 - 35 X _K	7,42 > 69	2,5	3 years

Nuclide	Half-life	Type	Nominal activity [kBq]	Photon energy [keV]	Photon yield [%]	Nominal uncertainty activity [%]	Certificate validity period
¹³³ Ba	10,539 (6) years	EGA 1	3	80,9979 302,8508	33,31 18,31	0,8	3 years
		EGA 3	80	356,0129	62,05		3 years
¹³⁷ Cs	30,05 (8) years	EGA 1	16	661,657	84,99	0,9	3 years
		EGA 3	300				3 years
¹⁵² Eu	13,522 (16) years	EGA 1	30	od 121 do 1528 keV	depends on energy	0,8	3 years
		EGA 3	450				3 years
²⁴¹ Am	432,6 (6) years	EGA 1	15	59,5409	35,92	0,6	3 years
		EGA 3	450				3 years

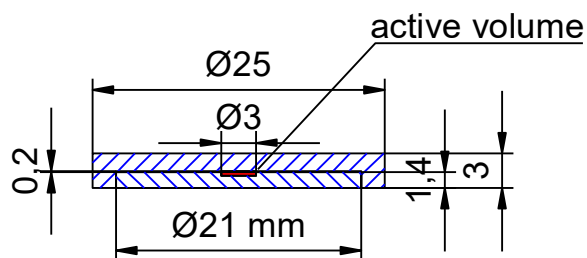

EGA 1, 3

STANDARDS TYPE MBSS/CBSS

Standards type MBSS are Marinelli beakers filled with silicone rubber containing uniformly distributed radionuclide or mixture of radionuclides. Default density of the active volume is $0,98 \text{ g.cm}^{-3}$ and mean atomic number approaches water. The standards are available in 3 types of polypropylene beakers with default volumes 450, 500 and 1000 ml. Standard type MBSS 20 is freely strewed KCl. Other volumes, nuclides, activities into the customer beakers are available on request as CBSS. Standards type MBSS/CBSS are open radionuclide sources.

Standards type MBSS/CBSS are used for energy and efficiency calibration of gamma spectrometers.

The standards are prepared from the standard solutions ER (EB) whose activity is determined by absolute method. The final sources are checked by measurement on gamma spectrometer with HPGe detector.

In the table below are normally used radionuclides and their activities. It is possible after consultation to produce sources with another radionuclides as MBSS X or activities as MBSS 4X (for example).

Type	Nuclide	Half-life	Nominal activity [kBq]	Nominal uncertainty activity [%]	Certificate validity period
MBSS 1	^{152}Eu	13,522 (16) years	3	1,5	3 years
MBSS 2	mixture *	-	40	-	3 years**
MBSS 3	^{134}Cs	2,0644 (14) years	3	1,2	3 years
MBSS 4	^{137}Cs	30,05 (8) years	3	1,5	3 years
MBSS 5	^{226}Ra	1600 (7) years	1,5	1,3	3 years
MBSS 6	^{57}Co	271,81 (4) days	2	1,4	3 years
MBSS 7	^{60}Co	5,2711(8) years	3	1,5	3 years
MBSS 8	^{241}Am	432,6 (6) years	10	1,2	3 years
MBSS 9	^{232}Th	14,02 (6) E+09 years	1	1,5	3 years
MBSS 12	^{133}Ba	10,539 (6) years	2	1,3	3 years
MBSS 13	^{109}Cd	461,9 (4) days	20	1,7	3 years
MBSS 14	^{210}Pb	22,23 (12) years	20	1,5	3 years
MBSS 16	^{85}Sr	64,850 (7) days	6	1,3	3 years
MBSS 17	^{54}Mn	312,19 (3) days	6	1,3	3 years
MBSS 18	^{88}Y	106,63 (5) days	10	1,5	3 years
MBSS 19	^{139}Ce	137,641 (20) days	2	1,6	3 years
MBSS 20	^{40}K	1,2504 (30) E+09 years	15,9 Bq/g KCl	2,5	3 years

* - for ^{241}Am , ^{133}Ba , ^{109}Cd , ^{139}Ce , ^{57}Co , ^{60}Co , ^{137}Cs , ^{85}Sr , ^{88}Y total nominal activity is 40 kBq. ^{51}Cr is added on request, nominal activity is 20 kBq.

** - for ^{51}Cr is certificate validity period 6 months

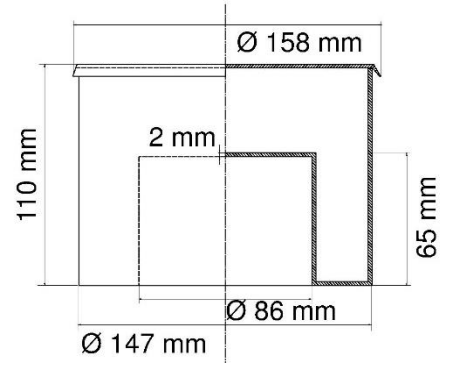
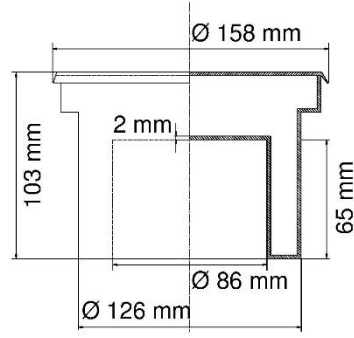
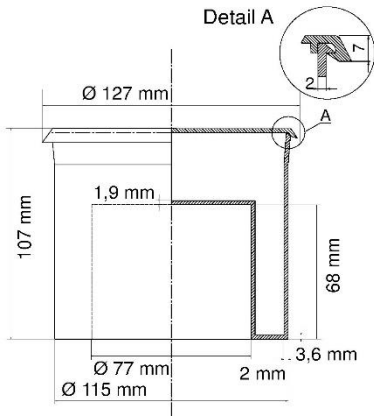

Type 0530G

Type 0540G

Type 1040G

STANDARDS TYPE EM

Standards type EM are surface emission sources with shape of disc. Radioactive substance is uniformly dropped on a plate of aluminium alloy in approx. 50 dots/cm². The active surface of the measurement standard is coated by the layer of protective lacquer and conductive layer 37 nm of aluminium deposited in vacuum. The areic mass of the protective layer is less than 0,3 mg/cm². Standards type EM are open radionuclide sources. Certificate validity period is 5 years.

Standard diameters of plates are 25,0; 30,0 and 48,5 mm. Another dimensions on request (max. diameter 170 mm). Minimal active diameter is 23 mm and maximal diameter respond to overall diameter. The thickness of plates is from 0,5 to 3 mm.

Standards are designed for efficiency calibration in measurements of various radionuclides in thin layer particularly for checking of relative measurements in surface, water, air and personnel contamination with α and β emitting radionuclides and for checking of stability of contamination monitors. For measurements of contamination can be used also standards EZ with larger active area.

The activity of the standard is calculated from the specific activity and mass of the standardized solution. Nominal uncertainty activity is < 1,5%. Surface emission is measured with windowless proportional counter with uncertainty for α and β (E > 150 keV) < 3% and for β (E < 150 keV) < 5%.

In the table below are normally used radionuclides and their activities. It is possible after consultation to produce sources with another diameters as EM X. Standards with U are produces only with aeric activity max. 1 Bq/cm², because of huge volume of mass.

Nuclide	Half-life years	Particle energy [keV]			Diameter of plate [mm]	Type	Nominal activity** [Bq]	Type X	Nominal activity** [Bq]
		α	β	γ					
¹⁴ C	5700 (30)	-	156,476	-	25,0	EM 1	20-500	EM 1X	600
					30,0	EM 10	20-700	EM 10X	850
					48,5	EM 145	20-1000	EM 145X	2200
³⁶ Cl	302 (4) E+03	-	709,53	511	25,0	EM 1	20-500	EM 1X	600
					30,0	EM 10	20-700	EM 10X	860
					48,5	EM 145	20-1000	EM 145X	2240
⁶⁰ Co	5,2711 (8)	-	317,32	1173 1332	25,0	EM 1	25-600	EM 1X	900
					30,0	EM 10	25-860	EM 10X	1300
					48,5	EM 145	25-1000	EM 145X	3350
⁹⁰ Sr	28,80 (7)	-	545,9 2278,7	-	25,0	EM 1	25-600	EM 1X	900
					30,0	EM 10	25-860	EM 10X	1300
					48,5	EM 145	25-1000	EM 145X	3350
¹³⁷ Cs	30,05 (8)	-	513,97 1175,63	661	25,0	EM 1	25-600	EM 1X	900
					30,0	EM 10	25-860	EM 10X	1300
					48,5	EM 145	25-1000	EM 145X	3350
¹⁴⁷ Pm	2,6234 (4)	-	224,1	-	25,0	EM 1	25-600	-	-
					30,0	EM 10	25-860	-	-
					48,5	EM 145	25-1000	EM 145X	2250
²⁰⁴ Tl	3,788 (15)	-	763,7	-	25,0	EM 1	25-300	-	-
					30,0	EM 10	25-430	-	-
					48,5	EM 145	25-1000	-	-

Nuclide	Half-life [years]	Particle energy [keV]			Diameter of plate [mm]	Type	Nominal activity ** [Bq]	Type X	Nominal activity** [Bq]
		α	β	γ					
U	*	4198 4774,6	-	-	25,0	EM 4	4,5-5	-	-
					30,0	EM 40	4,5-7	-	-
					48,5	EM 445	4,5-18,5	-	-
²³⁹ Pu	24100 (11)	5156,59	-	-	25,0	EM 4	4,5-150	-	-
					30,0	EM 40	4,5-220	-	-
					48,5	EM 445	4,5-560	-	-
²⁴¹ Am	432,6 (6)	5442,86 5485,56	-	59,5409	25,0	EM 4	4,5-600	-	-
					30,0	EM 40	4,5-860	-	-
					48,5	EM 445	4,5-1000	EM 445X	2250

* ²³⁸U - 4,468 (5) E+09 years ²³⁵U - 704 (1) E+06 years ²³⁴U - 2,455 (6) E+05 years

** nominal activity depends on maximal active area, values of the nominal activities are related only to standard dimensions of plates (diameters 25,0; 30,0 and 48,5 mm)

E.g. for Cs-137, diameter 23 mm (active area 4,15 cm²): max. nominal activity for EM 1 500 Bq
max. nominal activity for EM 1X 750 Bq

for Cs-137 diameter 25 mm (active area 4,91 cm²): max. nominal activity for EM 1 600 Bq
max. nominal activity for EM 1X 900 Bq

for Cs-137, diameter 23 mm (active area 4,15 cm²): max. nominal activity for EM 10 500 Bq
max. nominal activity for EM 10X 750 Bq

for Cs-137 diameter 30 mm (active area 7,07 cm²): max. nominal activity for EM 10 850 Bq
max. nominal activity for EM 10X 1 300 Bq

for Cs-137, diameter 23 mm (active area 4,15 cm²): max. nominal activity for EM 145 500 Bq
max. nominal activity for EM 145X 750 Bq

for Cs-137 diameter 48,5 mm (active area 18,47 cm²): max. nominal activity for EM 145 1000 Bq
max. nominal activity for EM 145X 3 400 Bq

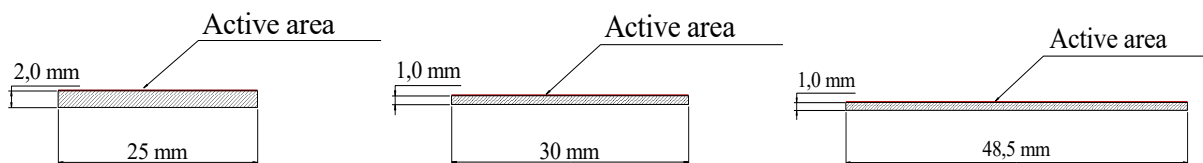

Type EM 1, 4

Type EM 10, 40

Type EM 145, 445

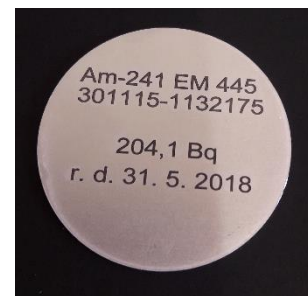
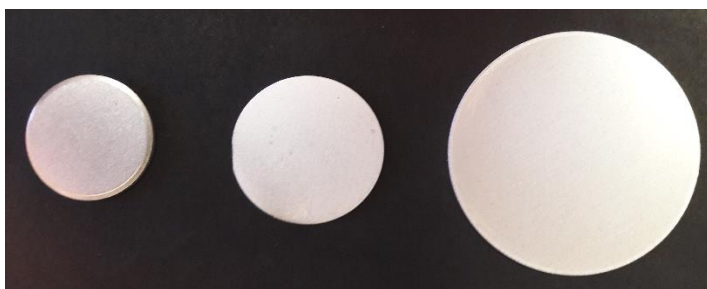

STANDARDS TYPE EZ

Standards type EZ are surface emission sources with rectangular shapes. Radioactive substance is uniformly dropped on a plate of aluminium alloy in approx. 50 dots/cm². The active surface of the measurement standard is coated by the layer of protective lacquer and conductive layer 37 nm of aluminium deposited in vacuum. The areic mass of the protective layer is less than 0,3 mg/cm². Standards type EZ are open radionuclide sources. Certificate validity period is 5 years.

Standard dimensions of plates are 200 x 140 mm. Another dimensions on request (max. 290 x 160 mm). Minimal active dimensions of active area is 30 x 30 mm and maximal dimensions respond to overall dimension of the plates. The thickness of plates is from 0,5 to 3 mm.

Standards are designed for efficiency calibration in measurements of various radionuclides in thin layer particularly for checking of relative measurements in surface, water, air and personnel contamination with α and β emitting radionuclides and for checking of stability of contamination monitors.

The activity of the standard is calculated from the specific activity and mass of the standardized solution. Nominal uncertainty activity is < 1,5%. Surface emission is measured with windowless proportional counter with uncertainty for α and β ($E > 150$ keV) < 3% and for β ($E < 150$ keV) < 5%.

In the table below are normally used radionuclides and their activities. It is possible after consultation to produce sources with another diameters as EZ X. Standards with U are produces only with aeric activity max. 1 Bq/cm², because of huge volume of mass.

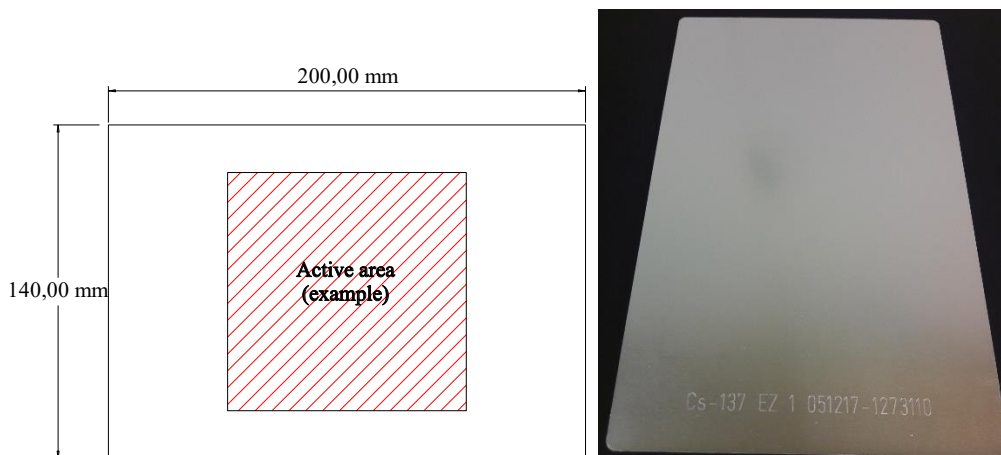

Nuclide	Half-life [years]	Particle energy [keV]			Type	Nominal activity** [Bq]	Type X	Max. nominal activity** [Bq]
		α	β	γ				
¹⁴ C	5700 (30)	-	156,476	-	EZ 1	20-10000	EZ 1X	34000
³⁶ Cl	302 (4) E+03	-	709,53	511	EZ 1	20-10000	EZ 1X	34000
⁶⁰ Co	5,2711 (8)	-	317,32	1173,22 1332,492	EZ 1	20-10000	EZ 1X	51000
⁹⁰ Sr	28,80 (7)	-	545,9 2278,7	-	EZ 1	20-10000	EZ 1X	51000
¹³⁷ Cs	30,05 (8)	-	513,97 1175,63	661,657	EZ 1	20-10000	EZ 1X	51000
¹⁴⁷ Pm	2,6234 (4)	-	224,1	-	EZ 1	20-10000	EZ 1X	51000
²⁰⁴ Tl	3,788 (15)	-	763,7	-	EZ 1	20-5000	EZ 1X	17000
U	*	4198 4774,6	-	-	EZ 2	4,5-280	-	-
²³⁹ Pu	24100 (11)	5156,59	-	-	EZ 2	4,5-8500	-	-
²⁴¹ Am	432,6 (6)	5442,86 5485,56	-	59,5409	EZ 2	4,5-10000	EZ 2X	34000

Note: * ²³⁸U - 4,468 (5) E+09 years ²³⁵U - 704 (1) E+06 years ²³⁴U - 2,455 (6) E+05 years

** nominal activity depends on maximal active area, values of the nominal activities are related only to standard dimensions of plate (200 x 140 mm)

E.g. for Cs-137 active area 100 x 50 mm (50 mm²): max. nominal activity for EZ 1 6 100 Bq
max. nominal activity for EZ 1X 9 100 Bq

for Cs-137 active area 150 x 110 mm (165 mm²): max. nominal activity for EZ 1 10 000 Bq
max. nominal activity for EZ 1X 30 000 Bq

for Cs-137 active area 200 x 140 mm (280 mm²): max. nominal activity for EZ 1 10 000 Bq
max. nominal activity for EZ 1X 51 000 Bq

STANDARDS TYPE EMM

Standards type EMM are surface emission sources with shape of discs. Radioactive substance is uniformly dropped on a plate of aluminium alloy in approx. 50 dots/cm². The active surface of the measurement standard is protected with Mylar foil. Thickness of Mylar foil is 0,005 mm and basis weight is 6,8 g/m². Standards type EMM are not suitable for radionuclides emitting low energy β -particles and α -particles. Certificate validity period is 5 years.

Standards EMM are sealed radioactive sources with classification ISO/14/C22323 according to ISO 2919. Leak tests are made according to ISO 9978 (wet wipe test).

Standard diameters of plates are 25,0; 30,0 and 48,5 mm. Another dimensions on request (max. diameter 170 mm). Minimal active diameter is 23 mm and maximal diameter respond to overall diameter. The thickness of plates is from 0,5 to 3 mm.

Standards are designed for checking of relative measurements in surface, water, air and personnel contamination with α and β emitting radionuclides and for checking of stability of contamination monitors. For measurements of contamination can be used also standards EZM with larger active area.

The activity of the standard is calculated from the specific activity and mass of the standardized solution. Nominal uncertainty activity is < 1,5%. Surface emission is measured with windowless proportional counter with uncertainty for α and β < 3%.

In the table below are normally used radionuclides and their activities. It is possible after consultation to produce sources with another diameters as EMM X.

Nuclide	Half-life [years]	Particles Energy [keV]		Diameter of plate [mm]	Type	Nominal activity * [Bq]	Type X	Max. nominal activity * [Bq]
		β	γ					
¹⁴ C	5700 (30)	156,476	-	25,0	EMM 1	50-1000	EMM 1X	5000
				30,0	EMM 10	50-1500	EMM 10X	7000
				48,5	EMM 145	50-4000	EMM 145X	18500
³⁶ Cl	302 (4) E+03	709,53	511	25,0	EMM 1	50-1000	EMM 1X	1000
				30,0	EMM 10	50-1500	EMM 10X	1500
				48,5	EMM 145	50-4000	EMM 145X	4000
⁶⁰ Co	5,2711 (8)	317,32	1173 1332	25,0	EMM 1	50-1000	EMM 1X	5000
				30,0	EMM 10	50-1500	EMM 10X	7000
				48,5	EMM 145	50-4000	EMM 145X	18500
⁹⁰ Sr	28,80 (7)	545,9 2278,7	-	25,0	EMM 1	50-1000	EMM 1X	5000
				30,0	EMM 10	50-1500	EMM 10X	7000
				48,5	EMM 145	50-4000	EMM 145X	18500
¹³⁷ Cs	30,05 (8)	513,97 1175,63	661	25,0	EMM 1	50-600	EMM 1X	4900
				30,0	EMM 10	50-860	EMM 10X	7000
				48,5	EMM 145	50-1000	EMM 145X	18500
¹⁴⁷ Pm	2,6234 (4)	224,1	-	25,0	EMM 1	50-1000	EMM 1X	1000
				30,0	EMM 10	50-1500	EMM 10X	1500
				48,5	EMM 145	50-4000	EMM 145X	4000
²⁰⁴ Tl	3,788 (15)	763,7	-	25,0	EMM 1	50-1000	EMM 1X	1000
				30,0	EMM 10	50-1500	EMM 10X	1500
				48,5	EMM 145	50-4000	EMM 145X	4000

* nominal activity depends on maximal active area, values of the nominal activities are related only to standard dimensions of plates (diameters 25,0; 30,0 and 48,5 mm)

E.g. for Cs-137, diameter 23 mm (active area 4,15 cm²): max. nominal activity for EMM 1 500 Bq
max. nominal activity for EMM 1X 4 200 Bq

for Cs-137 diameter 25 mm (active area 4,91 cm²): max. nominal activity for EMM 1 600 Bq
max. nominal activity for EMM 1X 4 900 Bq

for Cs-137, diameter 23 mm (active area 4,15 cm²): max. nominal activity for EMM 10 500 Bq
max. nominal activity for EMM 10X 4 200 Bq

for Cs-137 diameter 30 mm (active area 7,07 cm²): max. nominal activity for EMM 10 850 Bq
max. nominal activity for EMM 10X 7 100 Bq

for Cs-137, diameter 23 mm (active area 4,15 cm²): max. nominal activity for EMM 145 500 Bq
max. nominal activity for EMM 145X 4 200 Bq

for Cs-137 diameter 48,5 mm (active area 18,47 cm²): max. nominal activity for EMM 145 1000 Bq
max. nominal activity for EMM 145X 18 500 Bq

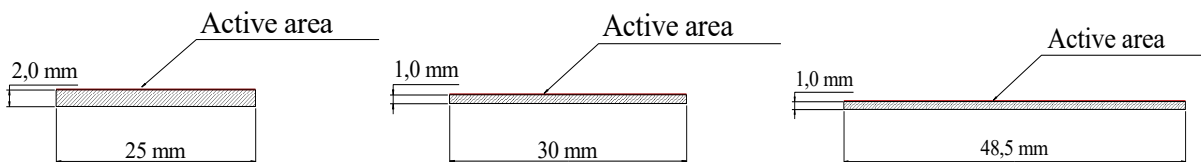

Type EMM 1, 4

Type EMM 10, 40

Type EMM 145, 445



STANDARDS TYPE EZM

Standards type EZM are surface emission sources with rectangular shapes. Radioactive substance is uniformly dropped on a plate of aluminium alloy in approx. 50 dots/cm². The active surface of the measurement standard is protected with Mylar foil. Thickness of Mylar foil is 0,005 mm and basis weight is 6,8 g/m². Standards type EZM are not suitable for radionuclides emitting low energy β -particles and α -particles. Certificate validity period is 5 years.

Standards EZM are sealed radioactive sources with classification ISO/14/C22323 according to ISO 2919. Leak tests are made according to ISO 9978 (wet wipe test).

Standard dimension of plates is 200 x 140 mm. Another dimensions on request (max. 300 x 180 mm). Minimal active dimension of active area is 30 x 30 mm and maximal dimension respond to overall dimension of the plates. The thickness of plates is from 0,5 to 3 mm.

Standards are designed for checking of relative measurements in surface, water, air and personnel contamination with α and β emitting radionuclides and for checking of stability of contamination monitors.

The activity of the standard is calculated from the specific activity and mass of the standardized solution. Nominal uncertainty activity is < 1,5%. Surface emission is measured with windowless proportional counter with uncertainty for α and β < 3%.

In the table below are normally used radionuclides and their activities. It is possible after consultation to produce sources with another diameters as EZM X.

Nuclide	Half-life [years]	Particle energy [keV]		Type	Nominal activity * [Bq]	Type X	Max. nominal activity * [Bq]
		β	γ				
¹⁴ C	5700 (30)	156,476	-	EZM 1	50-10000	EZM 1X	100000
³⁶ Cl	302 (4) E+03	709,53	511	EZM 1	50-10000	EZM 1X	50000
⁶⁰ Co	5,2711 (8)	317,32	1173,22 1332,492	EZM 1	50-10000	EZM 1X	280000
⁹⁰ Sr	28,80 (7)	545,9 2278,7	-	EZM 1	50-10000	EZM 1X	280000
¹³⁷ Cs	30,05 (8)	513,97 1175,63	661,657	EZM 1	50-10000	EZM 1X	280000
¹⁴⁷ Pm	2,6234 (4)	224,1	-	EZM 1	50-10000	EZM 1X	50000
²⁰⁴ Tl	3,788 (15)	763,7	-	EZM 1	50-10000	EZM 1X	50000

* nominal activity depends on maximal active area, values of the nominal activities are related only to standard dimensions of plate (200 x 140 mm)

E.g. for Cs-137 active area 100 x 50 mm (50 mm²): max. nominal activity for EZM 1 6 100 Bq
max. nominal activity for EZM 1X 50 000 Bq

for Cs-137 active area 150 x 110 mm (165 mm²): max. nominal activity for EZM 1 10 000 Bq
max. nominal activity for EZM 1X 165 000 Bq

for Cs-137 active area 200 x 140 mm (280 mm²): max. nominal activity for EZM 1 10 000 Bq
max. nominal activity for EZM 1X 280 000 Bq

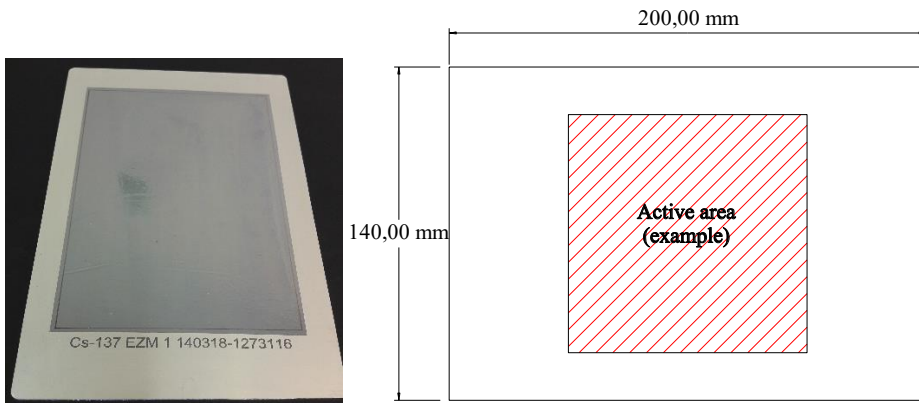

STANDARDS TYPE EB

Standards type EB are aqueous solutions of the appropriate quantity of ^{226}Ra . Chemical composition of the solution is: 1 g BaCl_2/l and 10 g HCl/l . EB00 is the aqueous solution of 1 g BaCl_2/l and 10 g HCl/l with very low and determined mass fraction of ^{226}Ra . Standards type EB are open radioactive sources.

The standards are designed for efficiency calibration of activity (mass) determination of ^{226}Ra or ^{222}Rn . Standard solutions are used either in the form of sealed ampoules for calibration or weighed part of the solution can be added to the analyzed sample as so called internal standard. After dilution by EB 00 solution is possible to prepare working standards with activities similar to measured samples. For emanometric detection of ^{226}Ra or ^{222}Rn in water, air and so on it is possible to transfer them to a washing bottle for which radon is expelled by a stream of gas.

Standard solutions are prepared by dissolving of ^{226}Ra content of standard ES activity of which was determined by comparison of gamma photon flux of the standard with the flux of CMI primary radium standards. Comparison is carried out by means of the $4\pi\text{-}\gamma$ ionization chamber.

Nuclide	Half-life [years]	Type	Mass of solution [g]	Nominal specific activity	Nominal uncertainty activity [%]	Packaging	Code	Certificate validity period
^{226}Ra	1600 (7)	EB 6	1	36,58 kBq/g	0,5	Glass ampoule 1 ml	RAB 6	3 years
		EB 7	1	3,658 kBq/g	0,5		RAB 7	3 years
		EB 8	1	365,8 Bq/g	0,5		RAB 8	3 years
		EB 9	1	36,58 Bq/g	0,6		RAB 9	3 years
		EB 10	1	3,658 Bq/g	0,7		RAB 10	3 years
		EB 65	5	36,58 kBq/g	0,5	Glass ampoule 5 ml	RAB 65	3 years
		EB 75	5	3,658 kBq/g	0,5		RAB 75	3 years
		EB 85	5	365,8 Bq/g	0,5		RAB 85	3 years
		EB 95	5	36,58 Bq/g	0,6		RAB 95	3 years
		EB 105	5	3,658 Bq/g	0,7		RAB	3 years

Note: ^{226}Ra is in the radioactive equilibrium with its short life daughter products

Activity of 1 g ^{226}Ra is $3,657 \cdot 10^{10}$ Bq

STANDARD TYPE EP

Standards type EP are mixtures of RaSO_4 and BaSO_4 poured into a cylindrical capsule, which is soldered and placed into a tube-shaped casing (length 13,5 - 26 mm and diameter 1,6 - 2,65 mm), which is then soldered as well. Both the capsule and the outer casing are made of an alloy composed of 90 % Pt and 10 % Ir. The total wall thickness is $0,5 \pm 0,05$ mm which is sufficient to absorb all alpha and beta radiation.

Standards EP are sealed radioactive sources with classification ISO/14/C65344 according to ISO 2919. Leak tests are made according to ISO 9978 (wet wipe test).

The standards are designed for calibration of dosimetric instruments, efficiency calibration in activity measurements of ^{226}Ra and other radionuclides. The calibration of dosimetric instruments is based on the knowledge that 1 g of ^{226}Ra with a 0,5 mm Pt filter has an exposure rate of $59,12 \times 10^{-9}$ A.kg⁻¹.

Mass of ^{226}Ra is determined by comparison with CMI primary radium standards by means of $4\pi\text{-}\gamma$ ionization chamber. Radiation of primary standards is filtered with 0,5 mm Pt.

Nuclide	Half-life [years]	Type	Nominal activity [MBq]	Nominal uncertainty activity [%]	Code	Certificate validity period
^{226}Ra	1600 (7)	EP 10	731,4	1,0	RAP-22	10 years
		EP 9	365,7	1,0	RAP-12	10 years
		EP 8	182,9	1,0	RAP-53	10 years
		EP 1	36,57	1,0	RAP-13	10 years
		EP 14	3,657	1,0	RAP-14	10 years
		EP 15	0,3567	1,0	RAP-15	10 years
		EP 16	0,03567	1,0	RAP-16	10 years

Note: Activity of 1 g ^{226}Ra is $3,657 \cdot 10^{10}$ Bq

STANDARDS TYPE ER

Standards type ER are water solutions of radionuclides. Approximately 1 or 5 g of the radioactive solution is sealed in a glass ampoule. Standards type ER are open radioactive sources.

Special type between solutionst is elementary ^{131}I (code IER). It is produced as set of 10 pieces of 2 ml glass penicillin bottle containing most often 30 kBq ^{131}I in tetrachlormethan solution each.

The standards are designed for efficiency calibration of all kinds of detectors, type ER 2 is especially suitable for the calibration of proportional, scintillation and GM counters, types ER 3 and ER X for ionisation chambers. Standard solutions are used either directly or after dilution for preparation of working standards. Application for internal standards is also possible.

Elementary iodine is used for checking and calibration of gas monitors in nuclear facilities, especially in nuclear power plants. Iodine can be released after evaporation in stream of carrier gas.

The ER 2 and ER 25 standards are directly prepared from a standard solution, the specific activity of which was determined by absolute measurement using the 4π (α , β , X, e) - γ coincidence method or by a 4π proportional counter. The specific activity of the ER 3 and ER X standards is calculated from the dilution ratio and the specific activity of ER 2 standard solution.

Activity of elementary iodine is determined by gamma spectrometry with HPGe detector.

Review of types and their parameters is in the table 1. In table 2 are assigned basic parameters and codes. It is possible after consultation to produce sources with activities or give the solution into the customer vessel as ER X.

Tab. 1

Type	Mass of solutin[g]	Nominal specific activitiy [MBq/g]	Nominal activity [MBq]	Packaging	Code
ER 1 *	1	0,005	0,005	Glass ampoule 1 ml	IZR 1(^{129}I)
ER 2	1	0,100	0,100	Glass ampoule 1 ml	...R 2
ER 25	5	0,100	0,500	Glass ampoule 5 ml	...R 25
ER 3	1	5	5	Glass ampoule 1 ml	...R 3
ER X	On request	On request	On request	On request	...R X

* applies to ^{129}I

Tab. 2

Nuclide	Half-life	Chemical composition of solution	Nominal uncertainty activity [%]	Code	Certificate validity period
^3H	12,312 (25) years	H_2O	1,7	HWR	3 years
^7Be	53,22 (6) days	30 mg BeSO_4 /l + 3 g HCl /l	1,0	BER	1 year
^{14}C	5700 (30) years	5 g Na_2CO_3 /l	1,5	CWR	3 years
^{22}Na	2,6029 (8) years	50 mg NaCl /l + 36 g HCl /l	0,8	NAR	3 years
^{24}Na	14,958 (2) hours	50 mg NaCl /l + 36 g HCl /l	0,6	NKR	3 days
^{32}P	14,284 (36) days	50 mg H_3PO_4 /l	0,6	PWR	2 months
^{35}S	87,25 (15) days	50 mg Na_2SO_4 /l	1,3	SWR	1 years
^{36}Cl	302 (4) E+03 years	40 mg NaCl /l	1,1	CLR	3 years
^{42}K	12,355 hours	100 mg KHCO_3 /l	0,6	KWR	3 days
^{45}Ca	162,64 (11) days	20 mg CaCl_2 /l + 3 g HCl/l	1,2	CAR	3 years
^{51}Cr	27,704 (4) days	30 mg CrCl_3 /l + 3 g HCl /l	0,8	CRR	6 months

Nuclide	Half-life	Chemical composition of solution	Nominal uncertainty activity [%]	Code	Certificate validity period
⁵⁴ Mn	312,19 (3) days	50 mg MnCl ₂ /l + 3 g HCl/l	0,6	MNR	3 years
⁵⁵ Fe	2,747 (8) years	50 mg FeCl ₃ /l + 3 g HCl/l	2,7	FMR	3 years
⁵⁶ Co	77,236 (26) days	20 mg CoCl ₂ /l + 3 g HCl/l	1,9	CBR	1 year
⁵⁷ Co	271,81 (4) days	20 mg CoCl ₂ /l + 3 g HCl/l	0,8	CTR	3 years
⁵⁸ Co	70,85 (3) days	20 mg CoCl ₂ /l + 3 g HCl/l	1,0	CYR	1 year
⁵⁹ Fe	44,464 (12) days	50 mg FeCl ₃ /l + 3 g HCl/l	0,8	FER	8 months
⁶⁰ Co	5,2711 (8) years	20 mg CoCl ₂ /l + 3 g HCl/l	0,4	COR	3 years
⁶³ Ni	98,7 (24) years	20 mg NiCl ₂ /l + 3 g HCl/l	1,5	NIR	3 years
⁶⁴ Cu	12,7004 (20) hours	50 mg CuCl ₂ /l + 3 g HCl/l	1,7	CUR	3 days
⁶⁵ Zn	244,01 (9) days	50 mg ZnCl ₂ /l + 3 g HCl/l	1,5	ZNR	3 years
⁶⁷ Ga	3,2613 (5) days	12,6 mg GaCl ₃ /l + 7 g HCl/l	1,2	GAR	15 days
⁷⁵ Se	119,781 (24) days	20 mg Na ₂ SeO ₃ /l + 4 g NaOH/l	1,0	SER	2 years
⁷⁶ As	1,094 days	50 mg Na ₃ AsO ₃ /l + 50 mg Na ₂ SO ₃ /l + 1g NaOH/l	1,3	ASR	5 days
⁸² Br	35,282 (7) hours	50 mg NH ₄ Br/l	1,0	BRR	7 days
⁸⁵ Sr	64,850 (7) days	20 mg SrCl ₂ /l + 3 g HCl/l	0,8	SAR	1 year
⁸⁶ Rb	18,642 (18) days	20 mg RbCl/l + 3 g HCl/l	0,8	RBR	3 months
⁸⁸ Y	106,626 (5) days	20 mg YCl ₃ /l + 3 g HCl/l	1,2	YWR	2 years
⁸⁹ Sr	50,57 (3) days	20 mg SrCl ₂ /l + 3 g HCl/l	0,6	SRR	1 year
⁹⁰ Sr	28,80 (7) years	20 mg Sr(NO ₃) ₂ /l + 20 mg Y(NO ₃) ₃ /l + 3 g HNO ₃ /l	0,6	STR	3 years
⁹⁰ Y	2,668 (13) days	50 mg YCl ₃ /l + 3 g HCl/l	0,6	YKR	10 days
⁹⁵ Zr	64,032 (6) days	12 mg (NH ₄) ₄ Zr(C ₂ O ₄) ₄ /l + 12 mg (NH ₄) ₃ NbO(C ₂ O ₄) ₃ /l + 0,5 g H ₂ C ₂ O ₄ /l	1,0	ZRR	1 year
⁹⁵ Nb	34,991 (6) days	12 mg (NH ₄) ₃ NbO(C ₂ O ₄) ₃ /l + 0,5 g	0,6	NBR	6 months
⁹⁹ Mo	2,748 (6) days	25 mg (NH ₄) ₂ MoO ₄ /l + 0,3 g NH ₄ OH/l	1,0	MOR	10 days
⁹⁹ Tc	211.5(11)E+03years	3 g NH ₄ OH /l	1,5	-	3 years
^{99m} Tc	6,0067 (10) hours	3 g NH ₄ OH/l	1,5	TCR	2 days
¹⁰³ Ru	39,247 (13) days	50 mg RuCl ₃ /l + 30 g HCl/l	1,2	RKR	6 months
¹⁰⁶ Ru	371,5 (21) days	50 mg RuCl ₃ /l + 50 mg RhCl ₃ /l + 30 g HCl/l	1,2	RUR	3 years
¹⁰⁹ Cd	461,9 (4) days	50 mg CdCl ₂ /l + 3 g HCl/l	1,3	CDR	3 years
^{110m} Ag	249,78 (2) days	20 mg AgNO ₃ /l + 6 g HNO ₃ /l	1,5	-	3 years
¹¹³ Sn	115,09 (3) days	50 mg H ₂ SnCl ₆ /l + 216 g HCl/l	1,2	SNR	2 years
¹²⁴ Sb	60,208 (11) days	50 mg SbCl ₃ /l + 70 g HCl/l	1,2	SBR	1 year
¹²⁵ I	59,388 (28) days	50 mg KI/l + 50 mg Na ₂ S ₂ O ₃ /l	0,6	ITR	1 year
¹²⁹ I	16,1 (7) E+06 years	4 g KI/l + 10 g Na ₂ S ₂ O ₃ /l	1,5	IZR	3 years
¹³¹ I	8,023 (19) days	50 mg KI/l + 50 mg Na ₂ S ₂ O ₃ /l	0,6	IWR	1 month
¹³¹ I	8,023 (19) days	2 µg I ₂ /ml CCl ₄	1,0	IER	1 month
¹³² Te	3,230 (13) days	50 mg Na ₂ TeO ₃ /l + 25 mg KI/l + 25 mg Na ₂ S ₂ O ₃ /l	1,6	TER	15 days
¹³³ Ba	10,539 (6) years	30 mg BaCl ₂ /l + 3 g HCl/l	0,6	BAR	3 years
¹³⁴ Cs	2,0644 (14) years	20 mg CsCl/l + 3 g HCl/l	0,8	CGR	3 years
¹³⁷ Cs	30,05 (8) years	20 mg CsCl/l + 3 g HCl/l	0,8	CSR	3 years
¹³⁹ Ce	137,641 (20) days	20 mg CeCl ₃ /l + 3 g HCl/l	0,8	CCR	2 years
¹⁴¹ Ce	32,503 (11) days	30 mg CeCl ₃ /l + 3 g HCl/l	0,8	CKR	6 months

Nuclide	Half-life	Chemical composition of solution	Nominal uncertainty activity [%]	Code	Certificate validity period
¹⁴⁴ Ce	284,89 (6) days	20 mg CeCl ₃ /l + 20 mg PrCl ₃ + 3 g HCl/l	1,0	CER	3 years
¹⁴⁷ Pm	2,6234 (4) days	20 mg PrCl ₃ /l + 20 mg NdCl ₃ + 3 g HCl/l	1,5	PMR	3 years
¹⁵² Eu	13,522 (16) years	30 mg EuCl ₃ /l + 3 g HCl/l	0,6	EUR	3 years
¹⁵⁴ Eu	8,601 (4) years	30 mg EuCl ₃ /l + 3 g HCl/l	3,3	-	3 years
¹⁵⁵ Eu	4,753 (14) years	30 mg EuCl ₃ /l + 3 g HCl/l	1,5	-	3 years
^{166m} Ho	1133 (8) years	36 g HCl/l	0,8	-	3 years
¹⁹² Ir	73,827 (13) days	50 mg Na ₂ IrCl ₆ /l + 3 g HCl/l	0,8	IRR	1 year
¹⁹⁷ Hg	2,673 days	50 mg Hg(NO ₃) ₂ /l + 4 g HNO ₃ /l + 50	1,5	HKR	10 days
¹⁹⁸ Au	2,6943 (3) days	50 mg KAu(CN) ₄ /l + 50 mg KCN/l	0,9	AUR	10 days
²⁰³ Hg	46,594 (12) days	50 mg Hg(NO ₃) ₂ /l + 4 g HNO ₃ /l + 50	1,0	HGR	7 months
²⁰⁴ Tl	3,788 (15) years	30 mg Tl ₂ SO ₄ /l + 3 g HNO ₃ /l	1,3	TLR	3 years
²⁰⁷ Bi	32,9 (14) years	30 mg BiCl ₃ /l + 3g HCl /l	2,2	-	3 years
²¹⁰ Po	138,376 (17) days	25 mg TeO ₂ /l + 63 g HNO ₃ /l	1,3	POR	2 years
²¹⁰ Pb	22,23 (12) years	20 mg Pb(NO ₃) ₂ /l + 20 mg Bi(NO ₃) ₃ /l +	1,3	PBR	3 years
²²⁹ Th	7932 (28) years	126 g HNO ₃ /l	0,8	-	3 years
²³² U	70,6 (11) years	126 g HNO ₃ /l	0,6	-	3 years
²³² Th	14,02 (6) E+09 years	315 g HNO ₃ /l	1,1	-	3 years
²³⁶ Pu	2,858 (8) years	126 g HNO ₃ /l	0,5	-	3 years
²³⁸ Pu	87,74 (3) years	63 g HNO ₃ /l	1,2	-	3 years
²³⁹ Pu	24100 (11) years	63 g HNO ₃ /l	1,2	PUR	3 years
²⁴¹ Pu	14,33 (4) years	63 g HNO ₃ /l	1,2	PUR	3 years
²⁴¹ Am	432,6 (6) years	20 mg Sm(NO ₃) ₃ /l + 6,3 g HNO ₃ /l	0,4	AMR	3 years
²⁴² Pu	3,73 (3) E+05 years	20 mg Sm(NO ₃) ₃ /l + 6,3 g HNO ₃ /l	0,4	AMR	3 years
²⁴³ Am	7367 (23) years	126 g HNO ₃ /l	1,4	-	3 years
U	*	1,66 g UO ₂ (NO ₃) ₂ /l + 6,3 g HNO ₃ /l	1,0	UER	3 years
U	*	UO ₂ (NO ₃) ₂ . 6H ₂ O solid 1,66 g	1,01,0	UESU	3 years
U	*	UO ₂ (NO ₃) ₂ . 6H ₂ O solid	1,0	UES	3 years

Note: * ²³⁸U – 4,468 (5) E+09 years, ²³⁵U – 704 (1) E+06 years, ²³⁴U – 2,455 (6) E+05 years



STANDARDS TYPE ESI

Standard type ESI is 1 ml of polymerised mixture of epoxy resin containing ^{241}Am and ^{129}I in the plastic test tube with dimensions 12 x 73 mm (diameter x length). Activities of ^{241}Am and ^{129}I are in such a ratio that resulting spectrum γ on a well type NaI(Tl) detector corresponds as much as possible with ^{125}I γ spectrum. Test tube is closed by plastic stopper. Standards type ESI are open radioactive sources. Certificate validity period is 5 years.

The standards are designed for the calibration and checking of RIA gamma counters, especially for the measuring of kits with ^{125}I .

The effective activity is determined by the comparison measurement with ^{125}I working standards using the gamma spectrometer with a well type NaI(Tl) detector 50 x 50. Nominal activity is 1500 Bq of ^{125}I . It is possible after consultation to produce sources with another radionuclides or activities as ESI X.

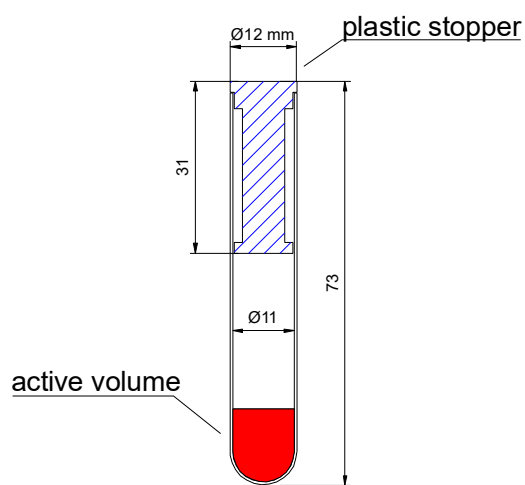

STANDARDS TYPE ENM

Standards type ENM are 10 ml penicillin vials with polyacrylamide gel and with active volume 5 ml. In case of breaking the vial, polyacrylamide gel prevents larger contamination. Standards type ENM are open radioactive sources.

The standards are used for calibration and checking of measuring devices in nuclear medicine, e.g. activity calibrators.

The activity of the standard is calculated from the specific activity and mass of the standardized solution and is checked by measurement in 4π ionization chamber.

In the tab below are normally used radionuclides and their activities. It is possible after consultation to produce sources with another radionuclides or activities as ENM X.

Nuclide	Half-life	Photon energy [keV]	Photon yield [%]	Nominal activity [MBq]	Nominal uncertainty activity [%]	Code	Certificate validity period
⁵⁷ Co	271,81 (4) days	122,06065	85,51	5	1,5	CTNM	5 years
		136,4735	10,71				
⁶⁰ Co	5,2711 (8) years	1173,23	99,85	5	0,8	CON M	5 years
		1332,49	99,9826				
¹³³ Ba	10,539 (6) years	53,162	2,14	5	1,2	BANM	5 years
		79,614	2,65				
		80,998	33,91				
		160,612	0,638				
		223,237	0,450				
		276,399	7,13				
		302,851	18,31				
		356,01	62,05				
383,85	8,94						
¹³⁷ Cs	30,05 (8) years	661,657	84,99	5	1,2	CSN	5 years
²⁴¹ Am	432,6 (6) years	59,54	35,92	5	1,0	AMN	5 years



STANDARDS TYPE ED

Standard type ED is a telescopic holder with activity source installed on the top of it. The source is a cylindrical plastic capsule with dimensions 11 x 9 mm (diameter x length), where the dried weighed part of standard solution of ^{57}Co is closed. Nominal activity is 5 MBq. Certificate validity period is 3 years.

Standard ED is sealed radioactive source with classification ISO/14/C22233 according to ISO 2919. Leak tests are made according to ISO 9978 (wet wipe test).

The source is used mainly as a marker in nuclear medicine.

The activity of the standard is calculated from the specific activity and mass of the standardized solution and is checked by measurement in 4π ionization chamber.

It is possible after consultation to produce sources with another radionuclides or activities as ED X.

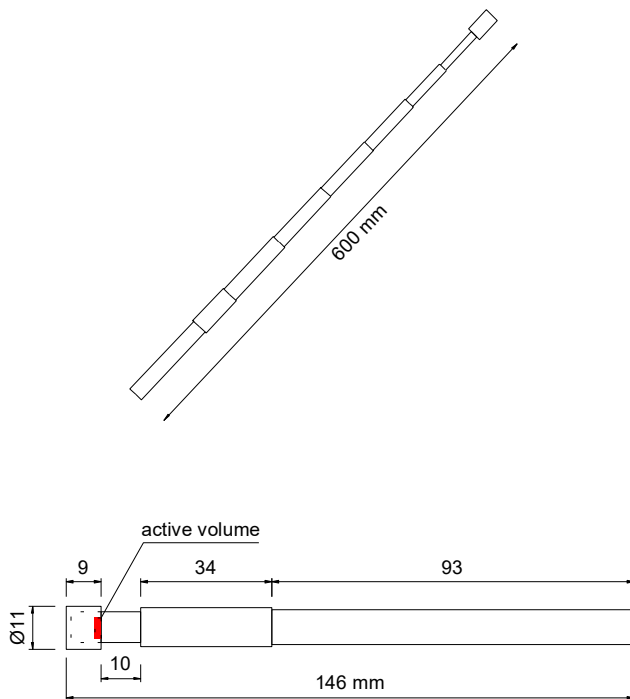

STANDARDS TYPE ENK / ENKV

The standard type ENK is a cylindrical capsule of aluminium alloy sealed with a stopper. Into this capsule is inserted a small brass capsule (ENKV) with activity adsorbed on the molecular sieve. The dimensions of the capsule of aluminium alloy are 54,0 x 21,5 mm and the dimensions of the small brass capsule are 18 x 6 mm (height x diameter).

Standards ENK / ENKV are sealed radioactive sources with classification ISO/14/C34324 according to ISO 2919. Leak tests are made according to ISO 9978 (wet wipe test).

The activity of the standard is calculated from the specific activity and mass of the standardized solution and is checked by measurement in 4π ionization chamber.

Type ENK is used as alternative to type ENM, which is used for checking of instruments for measuring activity in nuclear medicine. It is possible after consultation to produce sources with another radionuclides or activities as ENK X.

Nuclide	Half-life [years]	Photon energy [keV]	Photon yield [%]	Nominal activity [MBq]	Nominal uncertainty activity [%]	Code	Certificate validity period
¹³⁷ Cs	30,05 (8)	661,657	84,99	5	1,2	CSNK	15 years

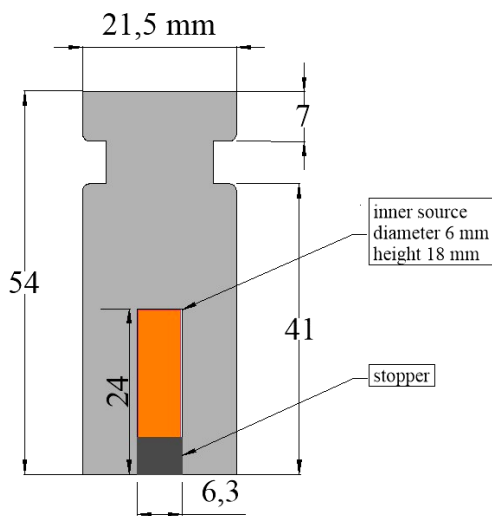

STANDARDS TYPE BOMAB

The Bottle Manequin Absorber Phantom (BOMAB) is the model of the human body 170 cm tall, separated into ten discrete parts, which can be independently filled. It is made from high density polyethylene, 4.8 – 5 mm thick, internal volume is approximately 55 dm³. It is supplied either empty or filled with non-active silicone resin with specific density near 1 g.cm⁻³ or filled with the same material containing activity, usually ¹⁵²Eu. The overall dimensions comply with requirements of Reference Man described in ICRP 23. Standards type BOMAB are open radioactive sources.

Certificate validity period is max. 10 years. It depends on used radionuclide.

BOMAB provides a functional simulation for the scattering of radiation in an adult human figure, to calibrate and check of whole body counters used for in vivo determination of deposited γ -emitting radionuclides.

The activity is calculated from the specific activity and the mass of used standard solutions and from mass of filler.

Dimensions of individual parts are in the table below.

Description	Number pcs	Shape	Profile, cm	Height, cm	Volume dm ³
head	1	ellipse	19 x 14	20	3,50
neck	1	circle	13 - diameter	10	1,00
thorax	1	ellipse	30 x 20	40	15,00
lumbar	1	ellipse	36 x 20	20	9,00
thigh	2	circle	15 - diameter	40	5,90
leg	2	circle	12 - diameter	40	3,60
arm	2	circle	10 - diameter	60	3,60



STANDARDS TYPE RF / RFE

Standards type RF / RFE are accurate and long term stable sources of defined activity of ^{222}Rn in gas phase with defined activity of parenteral ^{226}Ra . Radon is released from thin layer of a plastic foil on stainless steel plate with emanation power approaching 1 (RFE). The source type RF is constructed as a stainless steel cylindrical case supplied on the ends with the two ball valves and the two aerosol filters connected on the output aperture of the valves. All parts are made from stainless steel or Teflon. The sources are produced in activity range from 1 Bq to 2 MBq of ^{226}Ra . Standards type RF / RFE are open radioactive sources. Certificate validity period is 5 years.

The sources are designed for laboratory and field conditions. The main application is calibration of devices and detectors for activity measurements of ^{222}Rn and ^{226}Ra in environmental research. The user can apply the source in batch or flow through mode.

The activity of ^{226}Ra is calculated from the specific activity and the mass of used standard solutions and from mass of filler. The emanation power determined by gamma spectrometry on a HPGe detector and by measurement on NaI(Tl) detector.

Standards type RF with activity from 1 Bq to 900 Bq are labeled as RF 1L to RF 900L. Standards with activity from 1 kBq to 2000 kBq are labeled as RF 1 to RF 2000. It depends on nominal activity of source. Standards type RFE are labeled in the same way as type RF. Examples are in the table below.

Label	Activity
RF 10L / RF 10	10 Bq / 10 kBq
RF 20L / RF 20	20 Bq / 20 kBq
RF 100L / RF 100	100 Bq / 100 kBq
RF 200L / RF 200	200 Bq / 200 kBq

Specifications – RF a RFE	
Combined standard uncertainty of ^{226}Ra activity	$\geq 1,5 \%$
Emanation power	near 1, typical value 0,998
Working temperature and relative moisture (non-condensing)	0 - 40 ° C, 0 – 100 %
Specifications - RFE	
Dimensions	90 x 35 x 5 mm / 70 x 32 mm
Weight	55,8 g
Specifications - RF	
Internal volume	200 cm ³
Maximum flow of carrier gas	10 l/min.
Dimensions (length x diameter)	394 x 56 mm
Weight	1,3 kg

Type RF

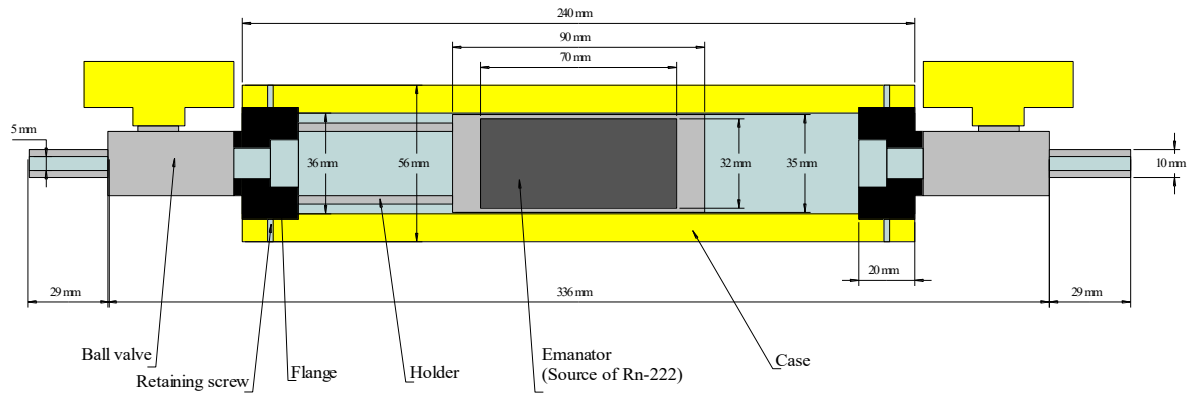

Type RFE

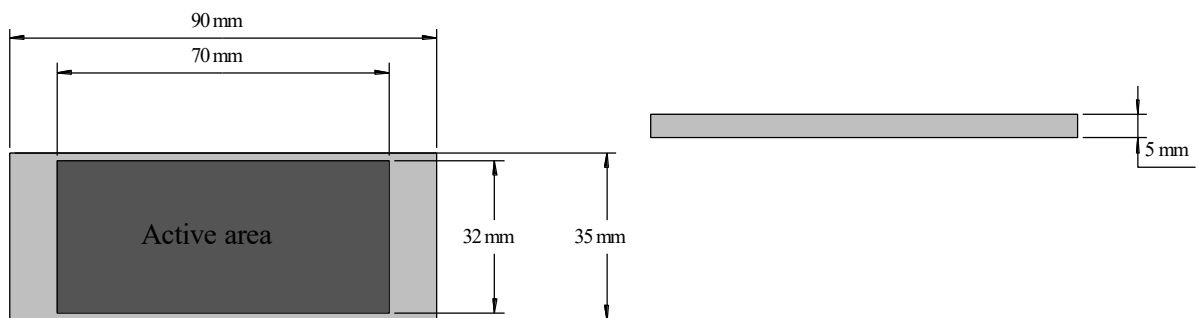

STANDARD TYPE ES

Cylinder shape standards type ES consist of outer case with inserted discs with activity. Activity is evenly deposited in points. Discs putting together originate a cylinder with approximately homogeneously deposited activity. The discs and the case are made from stainless steel DIN 1.4301. Standard dimension of cylinder is 35 x 15 mm, standard dimension of one discs are 34 x 0,8 mm (diameter x thickness). Other dimensions are made according to requirements of customer. The most common used radionuclides are ^{60}Co and ^{137}Cs (as ESCO and ESCS). Other radionuclides are also possible. Certificate validity period is 5 years.

Standards ES are sealed radioactive sources with classification ISO/14/C13223 according to ISO 2919. Leak tests are made according to ISO 9978 (wet wipe test).

Standards are designed for efficiency calibration of gamma spectrometers used for checking ^{137}Cs and ^{60}Co activity in steel. These radionuclides can occur in scrap iron as a result of liquidation of medical or industrial sources.

Activity of the standard is calculated from the mass and specific activity of the standard solution. Produced sources are checked with HPGe detector.

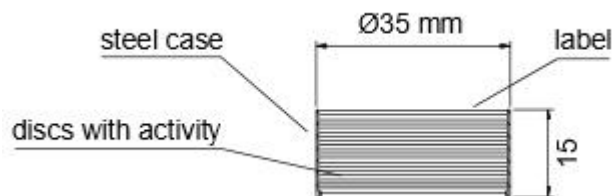

STANDARDS TYPE FILTER

Standards type FILTER are standards of radionuclides evaporated on the filters of materials (paper, textiles, paper captive charcoal, carbon cartridges etc.) used in air monitors. Standards are open radionuclide sources. Certificate validity period is normally 1 year, but laminated filter has 3 years validity period.

They are intended to calibrate monitoring devices by direct measurement or after separation of the radionuclide from filter in the manner prescribed for the monitoring system. They are manufactured according to requirements and after consultation with the customer (dimensions, materials, radionuclides and activity).

Activity is determined by calculation from the weight and specific activity of the standard solution.

METHYLIODIDE MARKED ^{131}I

Methyl iodide marked by ^{131}I is produced as a set of 10 pieces of 5 ml glass ampoules containing most often 30 kBq $\text{CH}_3^{131}\text{I}$ each, absorbed in 0,1 g sorbent for gas chromatography. After opening ampoule, methyl iodide can be released by heating on 200 - 250 ° C in stream of carrier gas (air, nitrogen). Content of CH_3I in ampoule is 2 µg (nominal values). Product is open radioactive source. Certificate validity period is 1 month.

Methyl iodide marked by ^{131}I is designed for checking of gas monitors in nuclear facilities, especially in nuclear power plants.

Activity of standards is determined by gamma spectrometry with HPGe detector.